

NOTES:

1. KID RECOMMENDS CONTRACTOR MEET ALL OF THE REQUIREMENTS ESTABLISHED FOR SAFE TRENCHING. (SEE OSHA AND UOSHA REQUIREMENTS, LATEST ADDITIONS.)
2. CONTRACTOR SHALL LOCATE ALL UNDERGROUND UTILITIES BEFORE LAYING PIPE WITHIN 50' OF SAID UTILITIES WHICH MAY BE EXPOSED, DAMAGED OR CROSSED AS SHOWN ON THE DRAWINGS OR AS "BLUE STAKED". THE CONTRACTOR WILL MAKE ARRANGEMENTS WITH THE UTILITY COMPANY TO MOVE THE UTILITY IF NECESSARY OR OBTAIN PERMISSION FROM THE DISTRICT ENGINEER TO MODIFY GRADE OF PIPELINE IN ORDER TO GO AROUND EXISTING UTILITIES.
3. TESTING: ALL NEW SANITARY SEWERS TO BE "TELEVISED" AND NECESSARY REPAIRS MADE BEFORE ACCEPTANCE. ALL LINES SHALL BE PRESSURE TESTED TO A 3.5 PSI MINIMUM. A MANDREL OR BALL CAN BE USED TO VERIFY DEFORMATION OF A PIPE AS DETERMINED FROM THE VIDEO UNLESS SPECIFIED OTHERWISE.
4. ALL SEWER LINES TO BE INSTALLED IN PUBLIC RIGHT-OF-WAY OR RECORDED SEWER EASEMENTS UNLESS OTHERWISE APPROVED BY THE KEARNS IMPROVEMENT DISTRICT.
5. KID INSPECTION OF PIPE BEDDING PLACEMENT AND PIPE ZONE BACKFILL IS REQUIRED PRIOR TO PLACEMENT OF TRENCH BACKFILL.
6. SEWER PIPE BEDDING: PIPE SHALL BE LAID ON A MINIMUM OF 6" OF 1" CLEAN GRAVEL.
7. SEWER LINE PIPE ZONE BACKFILL WITHIN THE PIPE ZONE SHALL BE 1" MINUS CLEAN GRAVEL PLACED A MINIMUM OF 1'-0" ABOVE THE TOP OF PIPE. COMPACTION OF FILL MATERIAL UNDER THE HAUNCHES OF THE PIPE IS REQUIRED.
8. BACKFILL ABOVE THE PIPE ZONE IS AS PER THE PREVAILING AUTHORITY.
9. PIPE LOCATION: INSTALL PIPE IN THE CENTER OF THE TRENCH.

DRAWN:
JW
CHECKED:
RL
CHECKED:



Typical Sewer Line Trench Detail

DATE:
7-24-2024
DRWG NO.:
S1

PROVIDE PRECAST RINGS TO BRING COVER TO PROPER ELEVATIONS.

CONCRETE COLLAR AROUND MANHOLE RING. MATCH FINISH GRADE.

MANHOLE COVER TO BE D&L FOUNDRY #A-1180 OR EQUAL. "KEARNS IMPROVEMENT DISTRICT" TO BE CAST INTO FACE. VENT HOLES TO BE 3/4".

CONE SECTION TO CONFORM WITH ASTM SPECIFICATION C-478.

STRAIGHT BACK PRECAST MANHOLE CONE

WALL SECTION TO BE MANUFACTURED AND REINFORCED IN CONFORMITY WITH ASTM SPECIFICATION C-478.

STANDARD PRECAST MANHOLE SECTIONS. DEPTH VARIES

NOTE: AFTER ALL GRADING AROUND MANHOLE HAS BEEN COMPLETE AND FINAL SURFACING IS IN PLACE, REMOVE DEBRIS AND TEMPORARY FALSE BOTTOM COVER.

3" MINIMUM FROM BOTTOM OF SECTION TO TOP OF HIGHEST PIPE.

3/4" PLYWOOD

PIPE NOT TO EXTEND MORE THAN 3" INTO MANHOLE.

3/4" MINUS GRAVEL

POUR MANHOLE BASE AFTER PIPES ARE IN PLACE OR USE PRECAST BASE

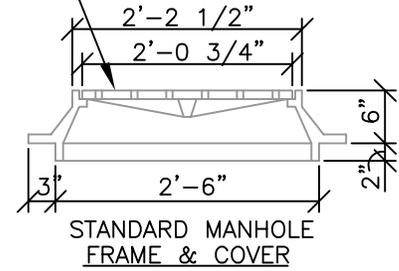
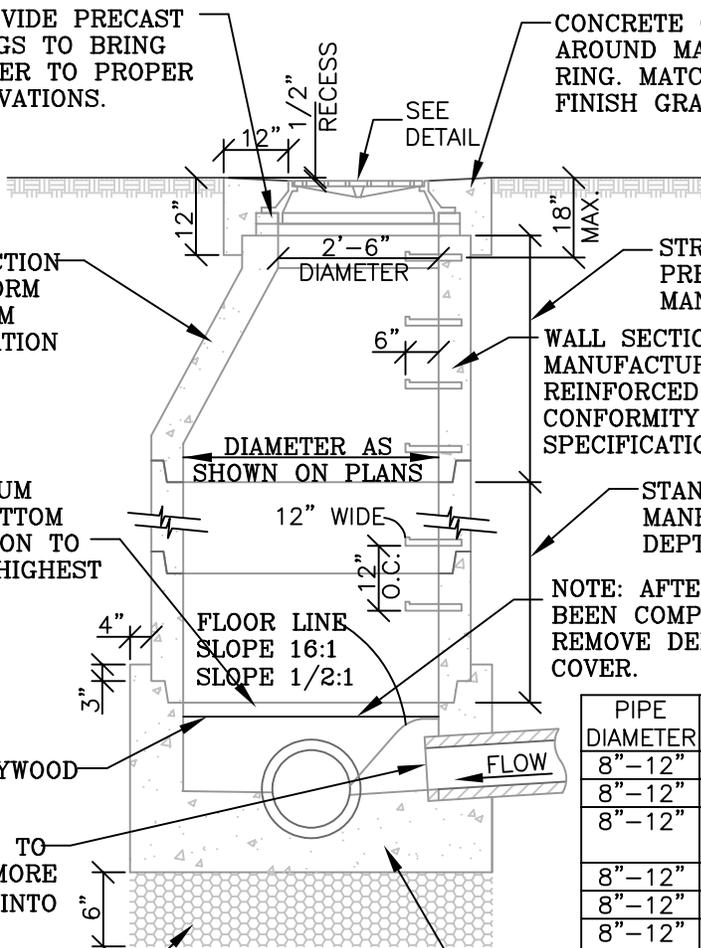

PIPE DIAMETER	SITUATION	MANHOLE DIAMETER
8"-12"	5' TO 12' - THRU FLOW	48"
8"-12"	INTERSECTION OF 3 OR MORE PIPES	60"
8"-12"	WHERE DEFLECTION OF THRU PIPE IS 45' OR GREATER	60"
8"-12"	12' TO 18' DEEP	60"
8"-12"	CONNECTING INTO AN EXISTING PIPE	60"
8"-12"	12" OR GREATER FALL THROUGH MANHOLE	60"
15"-18"	5' TO 18' DEEP - THRU FLOW	60"
8"-30"	18' DEEP OR GREATER	72"
15"-18"	WHERE DEFLECTION OF THRU PIPE IS 45' OR GREATER	72"
21"-36"	7' DEEP OR GREATER	72"
15"-36"	INTERSECTION OF 3 OR MORE PIPES	72"

TABLE 1

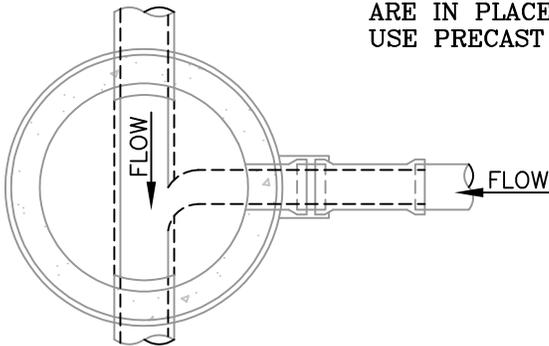

STANDARD MANHOLE PLAN VIEW

MINIMUM DROPS THRU SEWER MANHOLES	
ANGLE	DROPS ACROSS MANHOLE
GREATER THAN 90°	0.3'
75°-90°	0.2'
25°-75°	0.2'
0°-25°	NO LESS THAN GRADE OF DOWNSTREAM PIPE

TABLE 2

NOTES:

1. PROVIDE STUBS WHERE SHOWN ON THE PLAN DRAWINGS.
2. FURNISH & INSTALL 3/4" PLYWOOD FALSE BOTTOM COVERS IN ALL NEW OR EXISTING MANHOLES AROUND WHICH GRADING OR SURFACING IS BEING PERFORMED. PLYWOOD BOTTOMS TO BE REMOVED AFTER PAVING.
3. MANHOLES MAY BE 4'-0", 5'-0", OR 6'-0" AS SHOWN IN TABLE 1 OR AS SPECIFIED BY THE DISTRICT ENGINEER.
4. PROVIDE STEPS ON WALLS OF MANHOLE SECTIONS @ 12" O.C. AND POSITIONED UNDER OPENING. STEPS SHALL BE CAST-IN-PLACE, VIBRATED INTO GREEN CONCRETE, OR PRESS-FIT INTO PREFORMED HOLES IN WALLS.
5. STEPS SHALL BE CO-POLYMER POLYPROPYLENE COATED STEEL STEPS, MODEL PST-PF, AS MANUFACTURED BY M.A. INDUSTRIES, INC., OR ACCEPTABLE EQUAL.

DRAWN:
JW
CHECKED:
RL
CHECKED:



Standard Precast Manhole Detail

DATE:
7-24-2024
DRWG NO.:
S2

NOTE:
 ALL PIPE AND
 FITTINGS SHALL BE
 ASTM 3034 SDR 35.

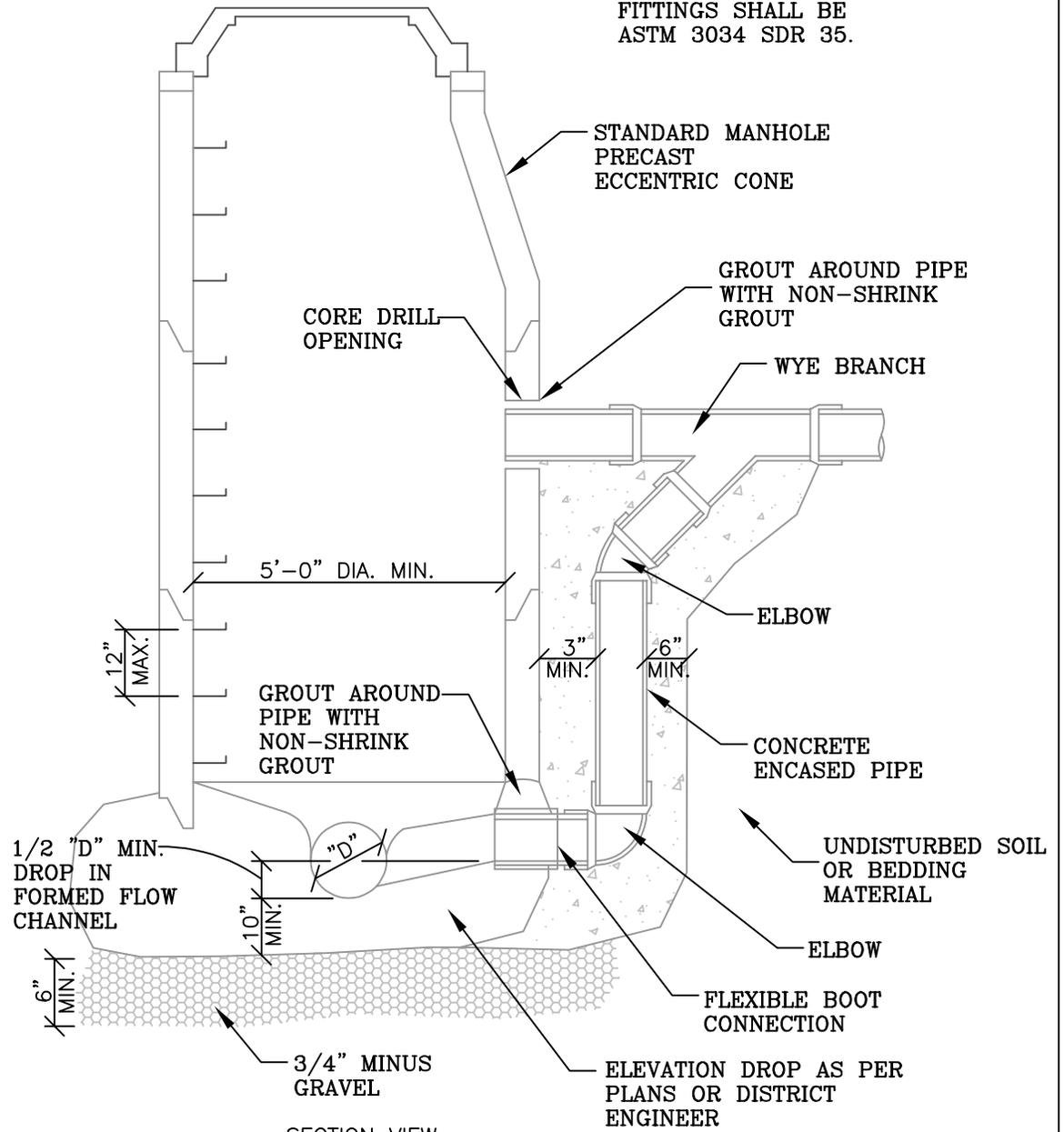

SECTION VIEW

NOTES:

1. INSPECTION: PRIOR TO BACKFILLING AROUND OUTSIDE DROP MANHOLE SECURE INSPECTION OF INSTALLATION BY DISTRICT INSPECTOR.
2. BACKFILLING: INSTALL ALL BACKFILL MATERIAL PER SPECIFICATION REQUIREMENTS.
3. CONCRETE: CLASS 4000 AS PER SPECIFICATIONS.
4. FINISH: PROVIDE SMOOTH AND NEAT FINISH ON INTERIOR OF GRADE RINGS.
5. FURNISH AND INSTALL 3/4" PLYWOOD FALSE BOTTOM COVER IN ALL NEW OR EXISTING MANHOLES AROUND WHICH GRADING OR SURFACING IS BEING PERFORMED.
6. DROP MANHOLES ARE TO BE USED ONLY WHEN APPROVED IN WRITING BY THE DISTRICT ENGINEER.
7. DROP MANHOLES REQUIRED FOR ANY LINE ENTERING MANHOLE TWO (2) FEET OR MORE ABOVE THE FLOWLINE OF MAIN LINE.

DRAWN:
 JW
 CHECKED:
 RL
 CHECKED:



Typical Outside Drop Manhole Detail

DATE:
 7-24-2024
 DRWG NO.:
S3

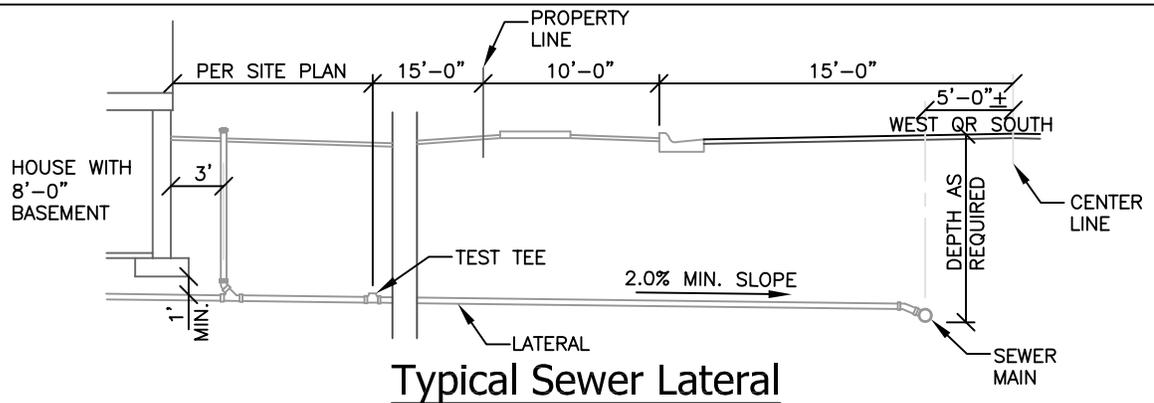

Typical Sewer Lateral

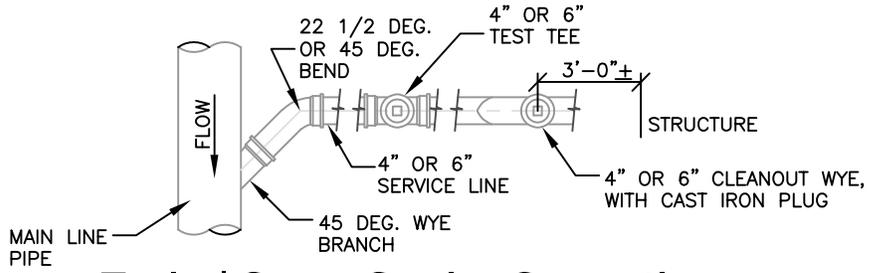

Typical Sewer Service Connection

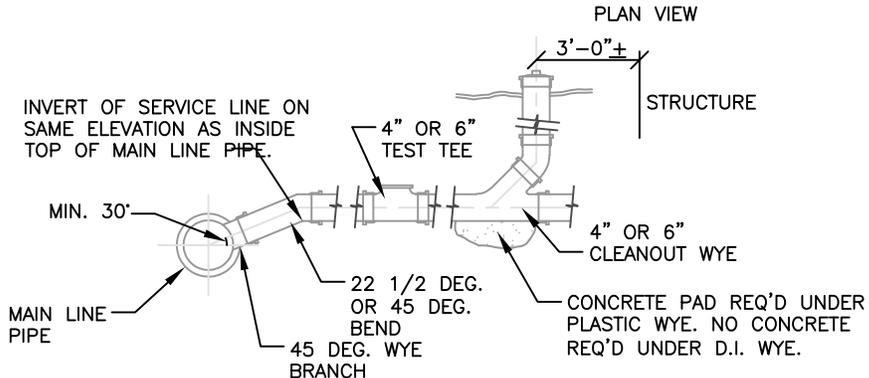

Typical Sewer Service Connection

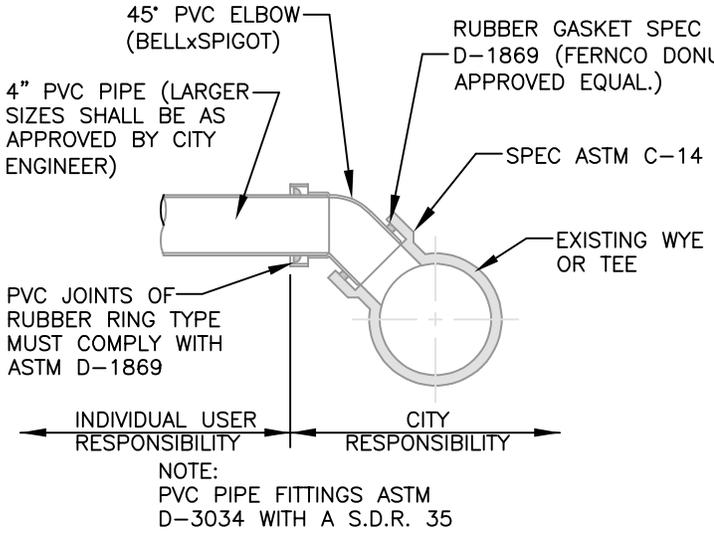

Connecting into Existing Wye or Tee

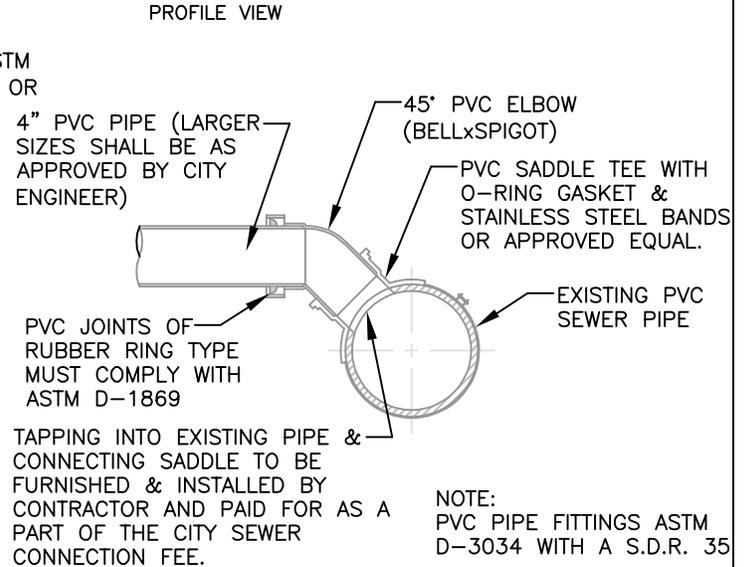

Tapping into Existing PVC Pipe

DRAWN:
JW
CHECKED:
RL
CHECKED:



Sewer Service Connection

DATE:
7-24-2024
DRWG NO.:
S4

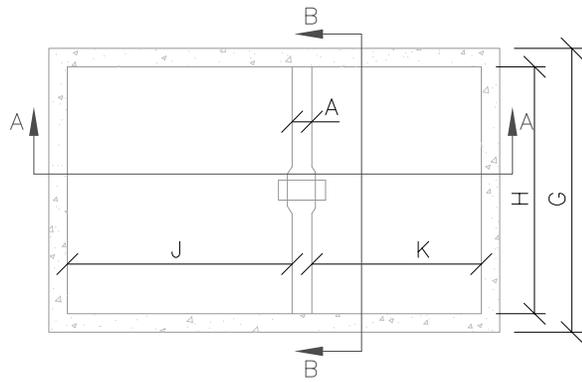

Box Plan View

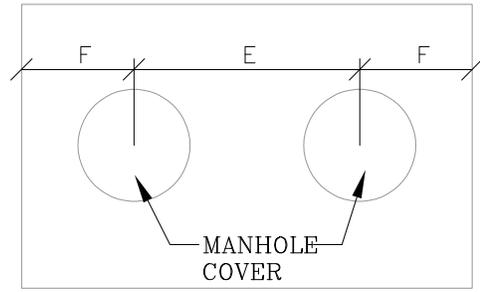

Lid Plan View

RING & COVER (A1180)
OR EQUAL, IF
APPROVED BY KID,
TYPICAL OF 2.

NO MORE THAN ONE
GRADE RING (1'
MAX.) PER RING &
COVER.

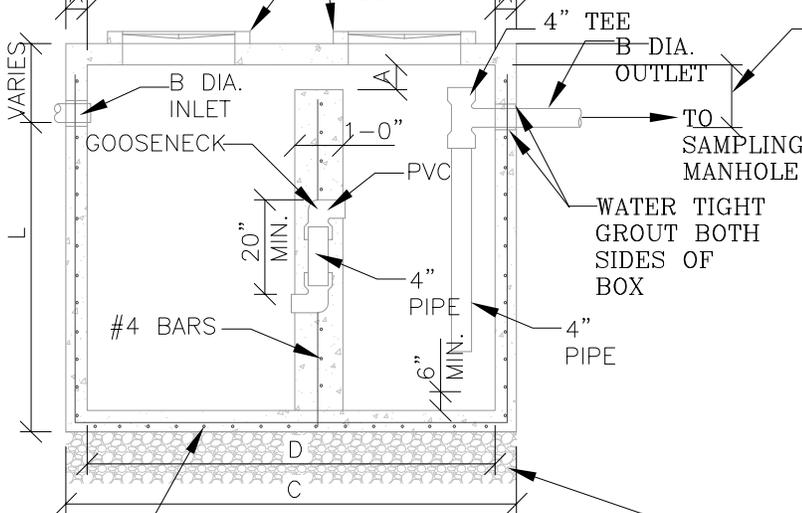

Section A-A

#4 @ 6" O.C.
EACH WAY
SEE NOTE 3

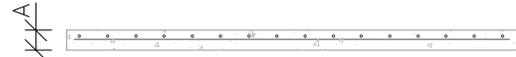

Lid Section

VARIES; +3"
FROM INLET

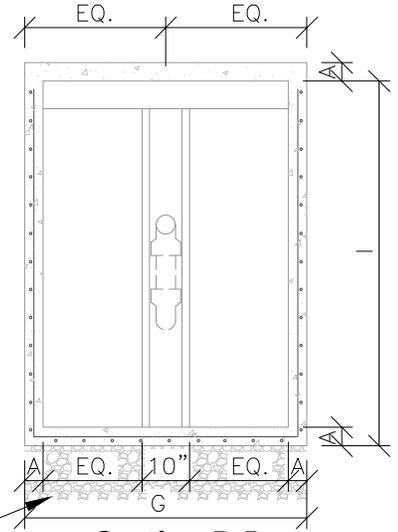

Section B-B

NOTES:

1. INSPECTION: PRIOR TO BACKFILLING AROUND CONCRETE BOX, SECURE INSPECTION OF INSTALLATION BY DISTRICT INSPECTOR.
2. BASE: PROVIDE 6" OF 3/4" MINUS GRAVEL UNDER GREASE TRAP.
3. IF PREFABRICATED GREASE TRAP IS USED, SUBMIT DESIGN DETAILS TO DISTRICT ENGINEER FOR APPROVAL.
4. SEE SS6 FOR SAMPLING MANHOLE DETAIL.
5. GREASE TRAP INTERCEPTOR SHALL BE 1,000 GAL. MINIMUM CAPACITY. THIS INTERCEPTOR IS NOT A REPLACEMENT FOR AN APPROPRIATELY SIZED AND LOCATED INDOOR GREASE INTERCEPTOR. INDOOR GREASE INTERCEPTORS SHALL COMPLY WITH ALL LOCAL & IPC REQUIREMENTS AND SPECIFICATIONS AND BE PLUMBING AND DRAINAGE INSTITUTE CERTIFIED.
6. COVER SHALL BE FLUSH WITH FINISH GRADE.
7. NO MORE THAN ONE GRADE RING (1' MAX.) ALLOWED PER RING AND COVER. IF MORE RISE IS REQUIRED A SHELL SECTION WITH CENTER WALL SHALL BE INSTALLED.
8. SANITARY SEWER (S.S.) SHALL NOT RUN THROUGH THE SAMPLING MANHOLE AND/OR GREASE INTERCEPTOR. S.S. SHALL BE CONNECTED TO THE SEWER LATERAL DOWNSTREAM FROM THE SAMPLING MANHOLE.
9. WHEN JOINING TWO PIPES OF DIFFERENT COMPOSITION, USE FERNCO COUPLERS. (NOTE: "NO HUB" BANDS ARE NOT ALLOWED).
10. BENDS TOTALING 90° MUST BE PROVIDED WITH A CLEANOUT.
11. DISTANCE BETWEEN CLEANOUTS NOT TO EXCEED 60'.
12. AT INSPECTION, FILL INTERCEPTOR WITH WATER ABOVE INLET AND OUTLET OF WATER TIGHT JOINTS.
13. GREASE INTERCEPTOR SHALL BE SUITABLE FOR H-20 LOADINGS.
14. 3/4" MINUS, OR PEA GRAVEL ARE TO BE USED FOR BEDDING AND BACKFILL.
15. GREASE INTERCEPTOR SHALL BE VENTED THROUGH BUILDING PLUMBING.

GREASE TRAP DIMENSIONS			
	1000 GAL.	1500 GAL.	2100 GAL.
A	6"	6"	8"
B	4"	4"	6"
C	9'-6"	9'-6"	13'-0"
D	8'-6"	8'-6"	12'-0"
E	5'-6"	5'-6"	8'-0"
F	1'-6"	1'-6"	2'-0"
G	5'-6"	5'-6"	7'-0"
H	4'-6"	4'-6"	6'-0"
I	4'-6"	6'-0"	5'-0"
J	5'-6"	5'-0"	8'-0"
K	3'-0"	3'-0"	4'-0"
L	3'-6"	3'-0"	4'-0"

L* MINIMUM

DRAWN:
JW
CHECKED:
RL
CHECKED:



Typical Grease Trap Detail

DATE:
7-24-2024

DRWG NO.:
S5

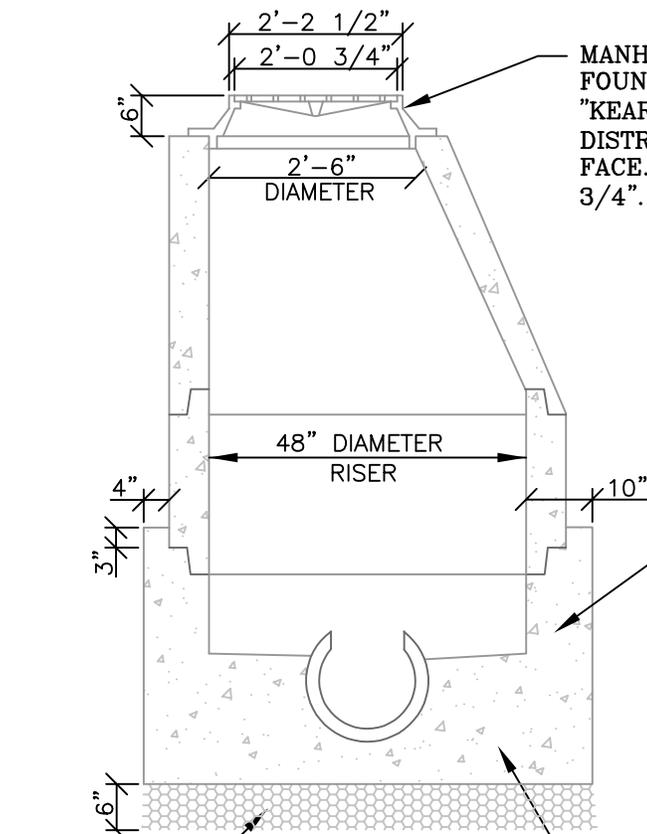

MANHOLE COVER TO BE D&L
FOUNDRY #A-1180 OR EQUAL.
"KEARNS IMPROVEMENT
DISTRICT" TO BE CAST INTO
FACE. VENT HOLES TO BE
3/4".

STANDARD
PRECAST MANHOLE
BASE

NOTES:

1. ALL LATERAL PLUGS SHALL BE SLIP IN SOLID PLASTIC PLUGS (BRANDT PLUGS ARE NOT ALLOWED).
2. IF DAMAGE IS CAUSED TO SEWER MAIN, DUE TO MANHOLE INSTALLATION AND/OR OTHER MEANS, CONTRACTOR WILL BE HELD RESPONSIBLE FOR REPAIRS.
3. SANITARY SEWER SHALL NOT RUN THROUGH THE SAMPLING MANHOLE AND/OR GREASE INTERCEPTOR. SANITARY SEWER SHALL BE CONNECTED TO THE SEWER LATERAL DOWNSTREAM FROM THE SAMPLING MANHOLE.
4. SAMPLING MANHOLE SHALL BE SUITABLE FOR H-20 LOADINGS.
5. THE EXISTING SEWER COLLECTION SYSTEM SHALL REMAIN IN SERVICE DURING CONSTRUCTION.
6. ALL MANHOLES SHALL HAVE A CONCRETE COLLAR PER A.P.W.A. PLAN 574.
7. SELECT BEDDING AND BACKFILL IS REQUIRED 6" UNDER, 12" ON SIDES AND 12" OVER SEWER SAMPLING MANHOLE, LATERAL, FITTINGS AND MAIN.
8. SELECT BEDDING AND BACKFILL SHALL BE 1" MINUS GRAVEL. PIPE BEDDING SHALL BE COMPACTED TO 95% MINIMUM ASTM D-1557.
9. MINIMUM TRENCH WIDTH SHALL BE EQUAL TO OUTSIDE PIPE DIAMETER PLUS ONE FOOT ON EACH SIDE OF PIPE.
10. TYPE OF PIPE SHALL BE P.V.C. SDR-35.
11. MINIMUM GRADE FOR 4" PVC SDR-35 IS 2% OR 1/4" PER FOOT.
12. BETWEEN TWO DIFFERENT MATERIALS, SUCH AS CLAY TO PVC, USE FERNCO COUPLERS OR EQUAL. NO HUB BANDS ARE NOT ALLOWED.
13. DISTANCE BETWEEN CLEANOUTS NOT TO EXCEED 60'.
14. BENDS TOTALING 90° MUST BE BACKED BY A CLEANOUT.
15. SEWER LATERALS MAY RUN UNDER A DRIVE APPROACH, PERMITTING TOP OF CLEANOUT IS NOT UNDER CONCRETE.

3/4" MINUS GRAVEL

**SAMPLING MANHOLE
PROFILE**

POUR MANHOLE
BASE AFTER PIPES
ARE IN PLACE OR
USE PRECAST BASE

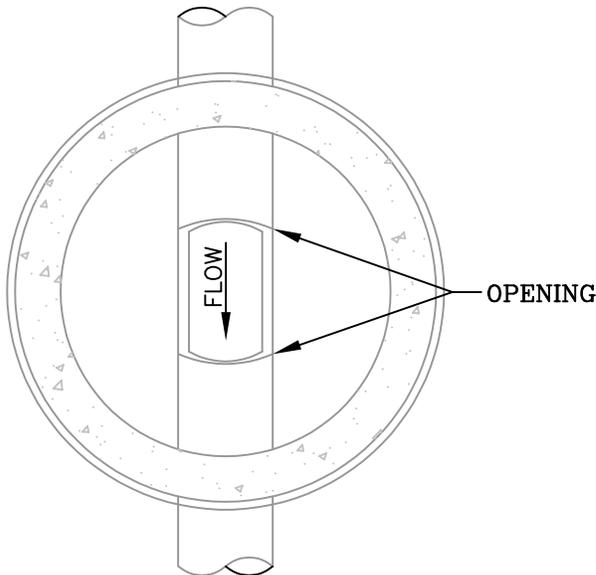

**SAMPLING MANHOLE
PLAN VIEW**

DRAWN:
JW

CHECKED:
RL

CHECKED:



Sampling Manhole Detail

DATE:
7-24-2024

DRWG NO.:
S6

NOTES:

1. INVERT D1 SHALL MATCH THE 0.75 DEPTH POINT OF D2, UNLESS OTHERWISE APPROVED BY DISTRICT ENGINEER.
2. AFTER ALL GRADING AROUND MANHOLE HAS BEEN COMPLETED AND FINAL SURFACING IS IN PLACE, REMOVE DEBRIS AND TEMPORARY PLUGS OR PLYWOOD FROM INSIDE OF MANHOLES.
3. STUBS FOR FUTURE CONNECTIONS SHALL BE PLUGGED UNTIL ACTIVATION FOR SERVICE IS APPROVED BY KEARNS IMPROVEMENT DISTRICT.

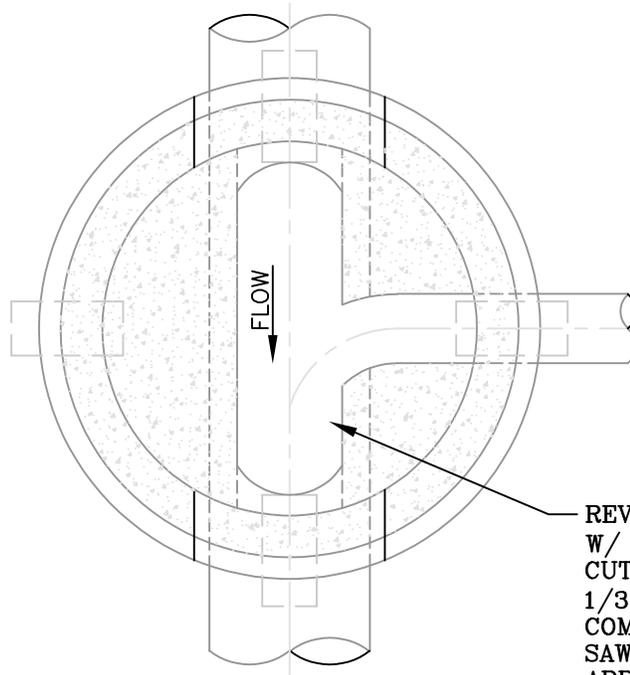

PLAN VIEW

REVIEW PIPE OPENING SIZE W/ INSPECTOR PRIOR TO CUTTING. SAWCUT UPPER 1/3 OF PIPE AFTER COMPLETION OF MANHOLE. SAWCUT FOR NEW PIPES AS APPROVED BY KEARNS IMPROVEMENT DISTRICT.

STANDARD PRECAST MANHOLE SECTIONS (DEPTH VARIES), SEE STANDARD MANHOLE DETAIL.

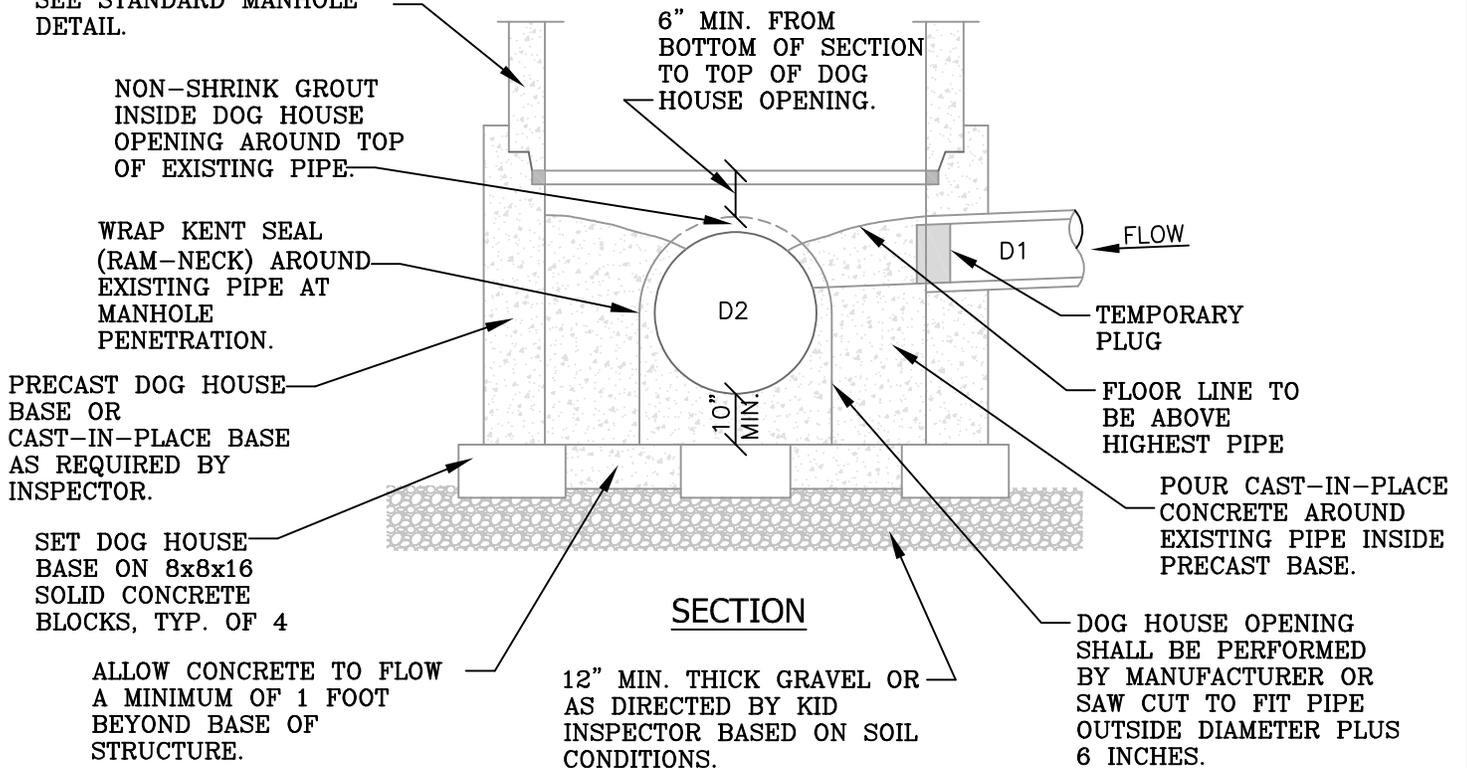

SECTION

DRAWN:

JW

CHECKED:

RL

CHECKED:



Sewer Manhole on Existing Pipe

DATE:

7-24-2024

DRWG NO.:

S7

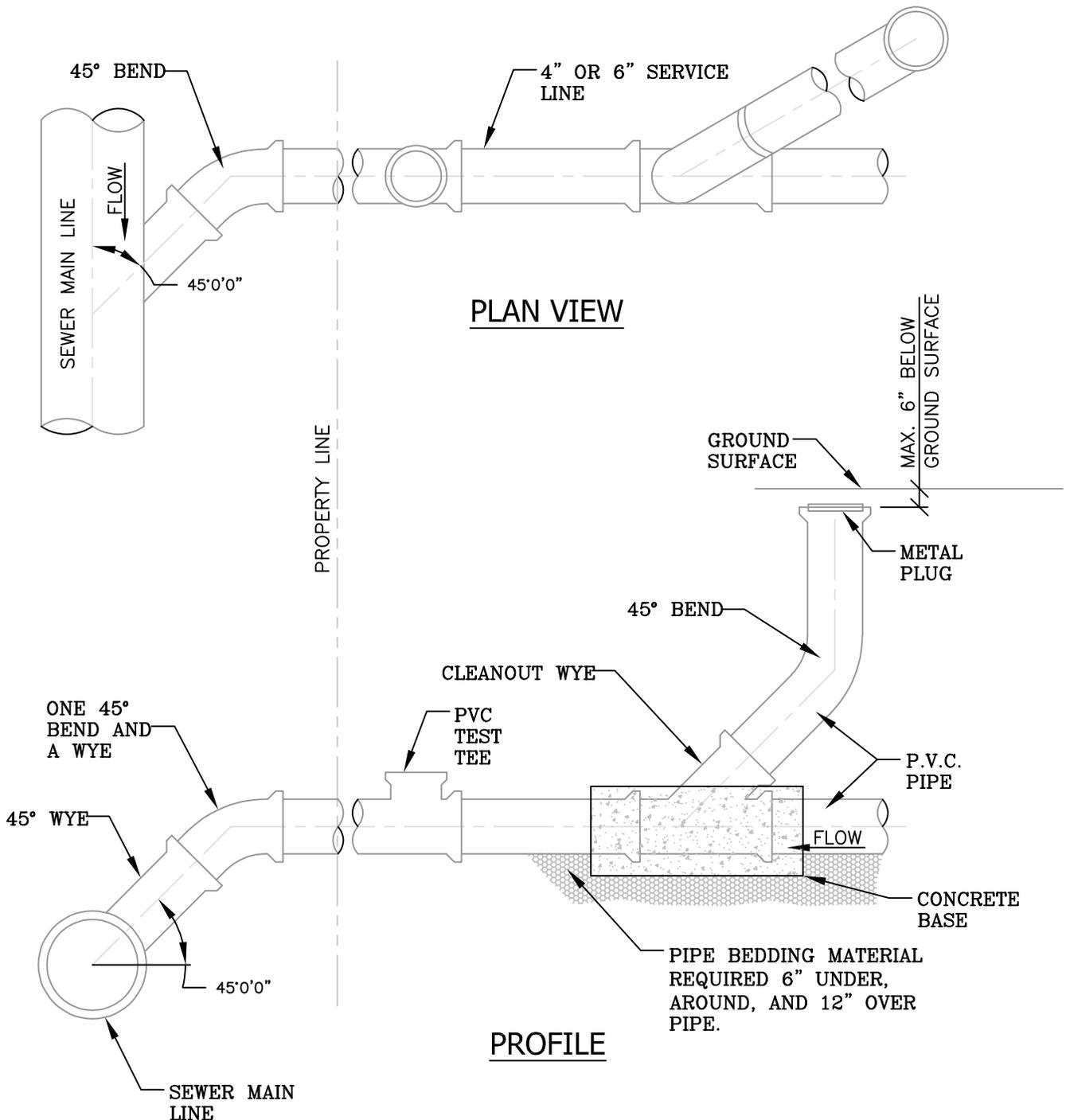

NOTES:

1. ALL SERVICES SHALL BE 4" DIAMETER MINIMUM AND SHALL BE EXTENDED FROM MAIN LINES TO 15' INSIDE OF PROPERTY LINES.
2. RECOMMENDED GRADE OF SEWER LATERALS IS 2%. WHERE IT IS IMPRACTICAL TO RUN SEWER LATERALS AT 2% DUE TO THE DEPTH OF THE SEWER MAIN LINE, SEWER LATERALS MAY BE RUN AT 1% GRADE WHEN APPROVED BY THE DISTRICT ENGINEER.
3. CLEANOUTS SHALL BE INSTALLED EVERY 70 FEET.
4. ALL 90° CONNECTIONS TO MAIN MUST BE CONSTRUCTED WITH LONG SWEEP 90° BEND.
5. DIRECT NOSE-ON CONNECTIONS ARE USED WHEN CONNECTING TO EXISTING MAIN LINE.

DRAWN: JW		<h1 style="margin: 0;">Typical Standard Sewer Service Connection & Cleanout</h1>	DATE: 7-24-2024
CHECKED: RL			DRWG NO.:
CHECKED:			S8

SEAL EACH END OF CASING WITH 1/8-INCH THICK SYNTHETIC RUBBER, MODEL C PULL-ON TYPE END SEALS, AS MANUFACTURED BY PIPELINE SEAL AND INSULATOR, INC. OR EQUAL, LINK-SEAL AT EACH END OF CASING

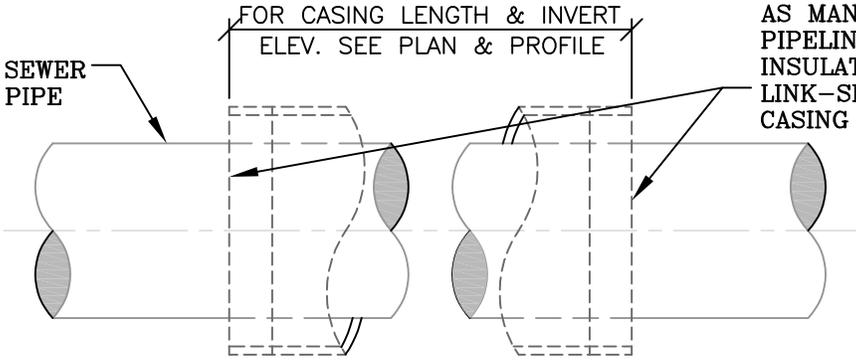

ANY VOIDS CREATED BY BORING, JACKING, OR TUNNELING SHALL BE FILLED BY PRESSURE GROUTING

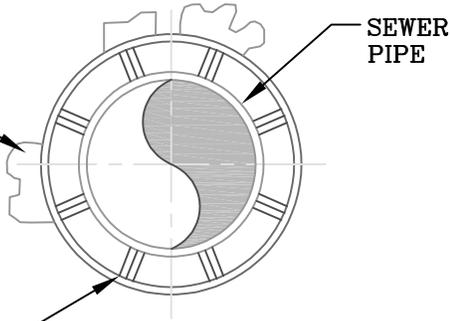

Section

CASING SPACERS MANUFACTURED BY PIPELINE SEAL AND INSULATOR, INC. MODEL 512G-2 SPACED EVERY 5-FT TO CENTER THE PIPE INSIDE THE CASING. PIPE THROUGHOUT THE LENGTH OF THE CASING SHALL BE AT A CONTINUOUS GRADE AS SHOWN ON DRAWINGS.

PIPE SIZE	MINIMUM I.D. CASING SIZE	MINIMUM WALL THICKNESS
4"	12"	0.188"
6"	16"	0.312"
8"	18"	0.312"
12"	24"	0.438"
16"	30"	0.50"
18"	30"	0.50"
24"	36"	0.625"
30"	42"	0.625"

LARGER CASINGS AS DIRECTED BY THE DISTRICT ENGINEER

NOTES:

1. CASING PIPES SHALL BE REQUIRED AS INDICATED ON THE DRAWINGS AND/OR WHERE REQUIRED BY THE DISTRICT INSPECTOR OR ENGINEER.
2. CARRIER PIPE SHALL BE TESTED BEFORE SEALING THE ENDS OF THE CASING.
3. SPACERS SHALL BE SECURELY ATTACHED TO THE CARRIER PIPE PER THE MANUFACTURER'S REQUIREMENTS.
4. CASING PIPE SHALL BE WELDED STEEL, ASTM A53, GRADE B OR APPROVED EQUIVALENT.

DRAWN:
JW
CHECKED:
RL
CHECKED:



Steel Casing for Sewer Pipe

DATE:
7-24-2024
DRWG NO.:
S9

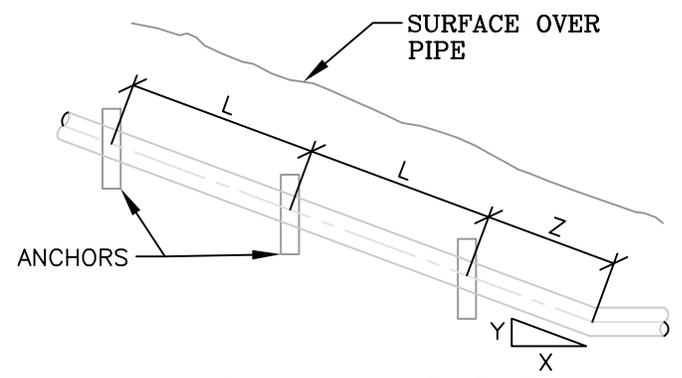
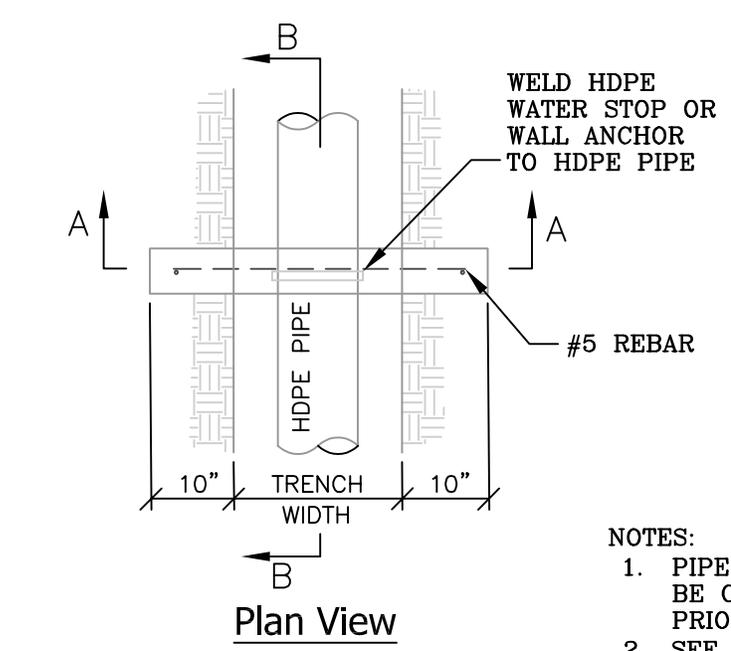
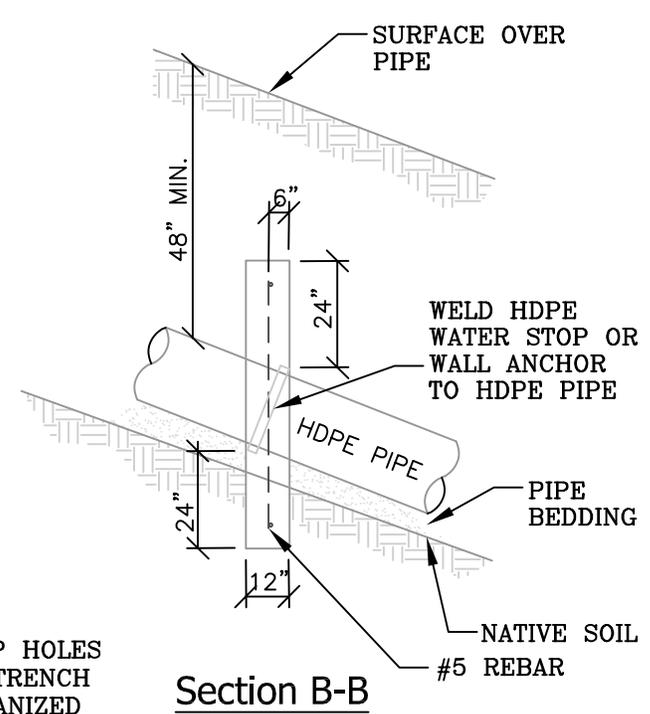
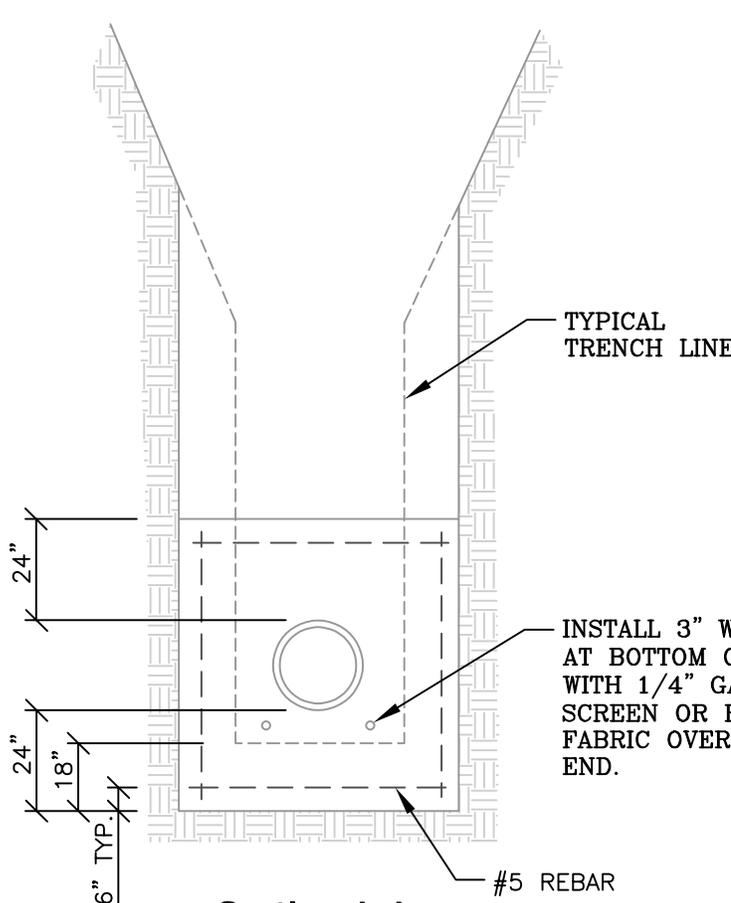

TABLE "A"

PIPE SLOPE (%) Y/X	L DISTANCE (MAX)	Z DISTANCE (MAX)
15-35	36'	36'
35-50	24'	24'
50 & OVER	16'	12'

- NOTES:
1. PIPE ANCHOR WALLS (CLASS 3000 CONCRETE) SHALL BE CONSTRUCTED USING FORMS. REMOVE FORMS PRIOR TO BACKFILLING TRENCH.
 2. SEE TABLE "A" FOR SPACING OF ANCHORS VERSUS PIPE SLOPES.

DRAWN:
JW

CHECKED:
RL

CHECKED:



Sewer Pipe Anchor Detail

DATE:
7-24-2024

DRWG NO.:
S10

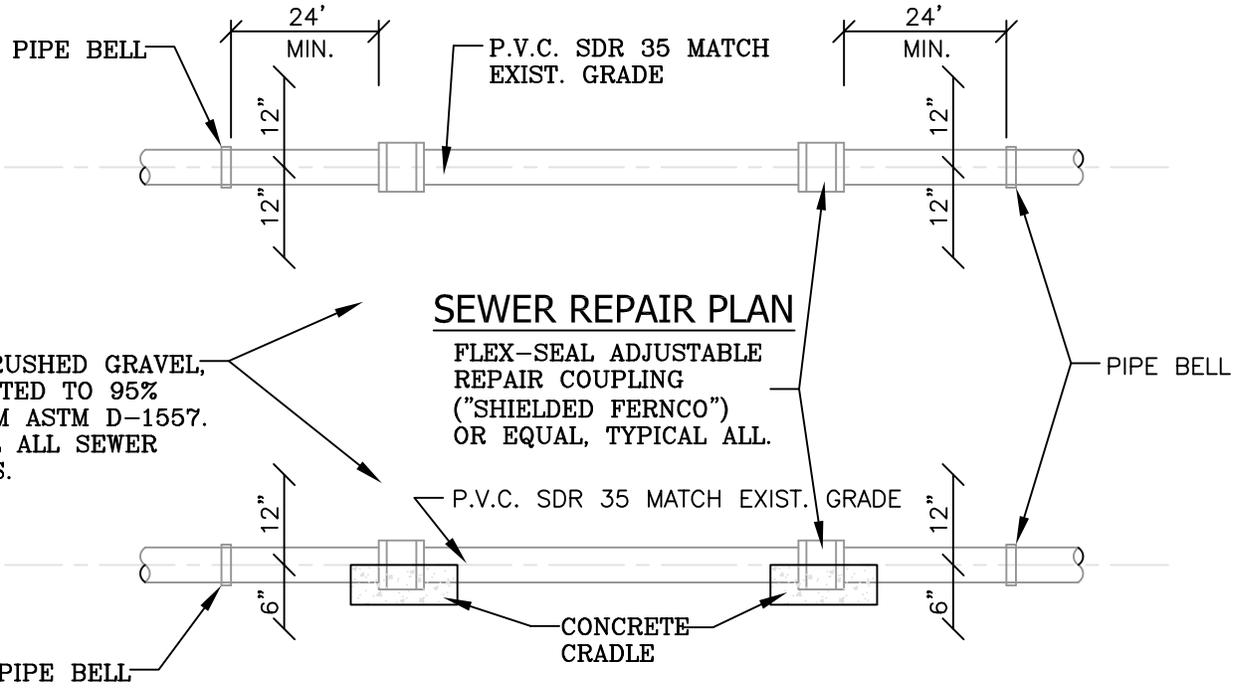

SEWER REPAIR PLAN

FLEX-SEAL ADJUSTABLE REPAIR COUPLING ("SHIELDED FERNCO") OR EQUAL, TYPICAL ALL.

SEWER REPAIR PROFILE

1/4" CRUSHED GRAVEL, COMPACTED TO 95% MINIMUM ASTM D-1557. TYPICAL ALL SEWER REPAIRS.

NOTES:

1. SELECT BEDDING AND BACKFILL IS REQUIRED 6" UNDER, 12" ON SIDES AND 12" OVER PIPE, FITTINGS & MAIN.
2. IF DAMAGE IS CAUSED TO SEWER MAIN, DUE TO NOSE-ON AND/OR OTHER MEANS, CONTRACTOR WILL BE HELD RESPONSIBLE FOR REPAIRS.
3. SEWER SHALL BE VIDEO INSPECTED AND VIDEO PROVIDED TO KEARNS IMPROVEMENT DISTRICT.
4. IF EXCAVATION IS WITHIN 2 FEET OF A BELL, CONTRACTOR TO REMOVE BELL AND EXTEND REPAIR TO CUT.

DRAWN:
JW
CHECKED:
RL
CHECKED:



Typical Sewer Repair Detail

DATE:
7-24-2024
DRWG NO.:
S11

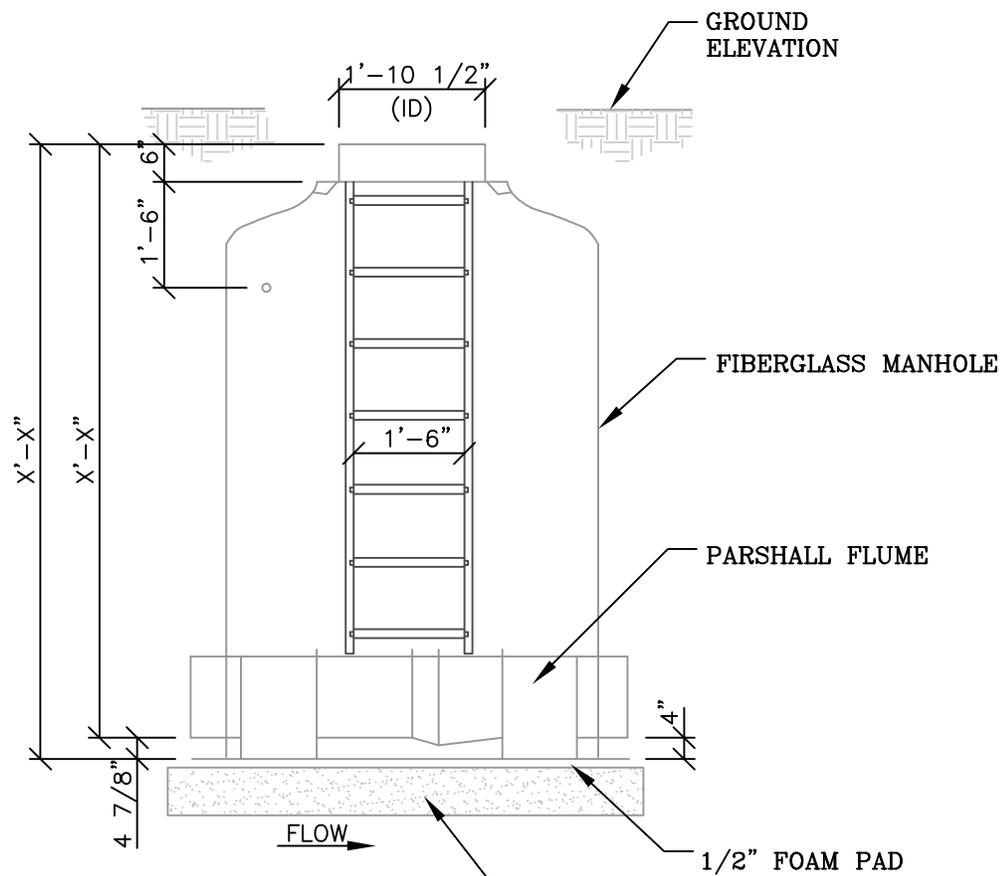
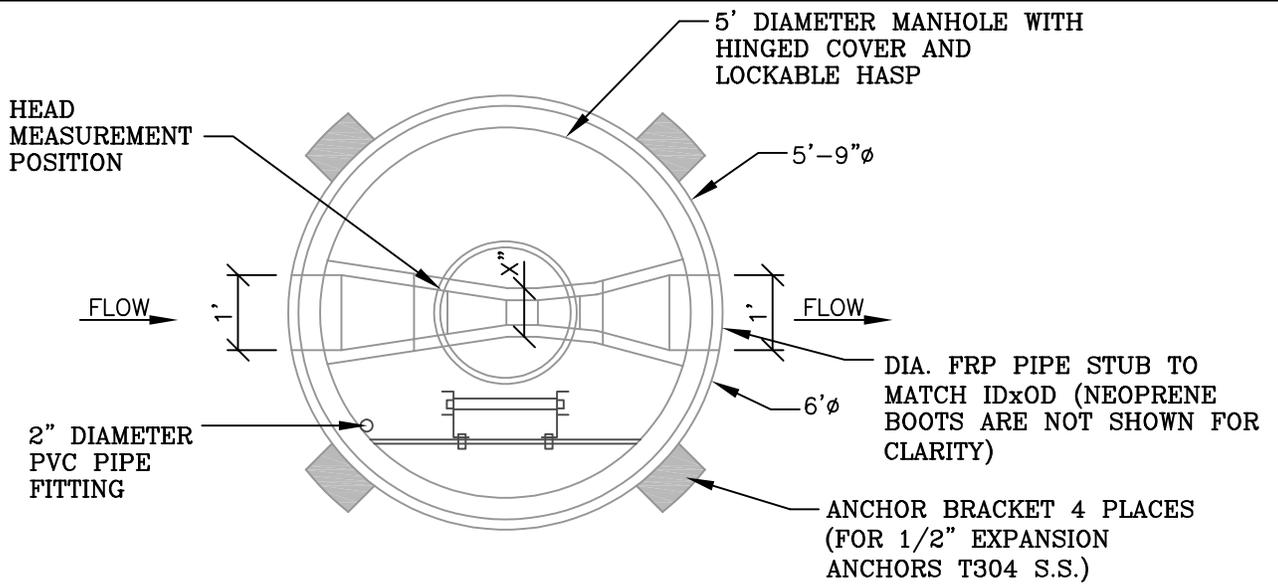

NOTES:

1. HINGE, HASP, ANCHOR BRACKETS & BOLTS ARE T-304 S.S.
2. THE MANHOLE BARREL IS 1/2" MINIMUM THICK FRP.
3. NEOPRENE BOOTS ARE SECURED WITH S.S. BANDS.
4. THE MATERIAL IS FRP (FIBERGLASS REINFORCED POLYESTER)

6" CONCRETE PAD PER MANUFACTURER'S SPECIFICATIONS ON 12" AGGREGATE BASE COMPACTED TO 95% RELATIVE COMPACTION.

DRAWN: JW
CHECKED: RL
CHECKED:



60" Diameter Sewer Metering Manhole & Parshall Flume

DATE: 7-24-2024
DRWG NO.: S12

1. A PREFABRICATED 5' DIAMETER FIBERGLASS METERING MANHOLE. (VIRTUAL POLYMER COMPOUNDS OR APPROVED EQUAL) MEETING THE REQUIREMENTS OF ANSI/ASTM D-3753 STANDARD SPECIFICATIONS FOR FIBER-REINFORCED MANHOLES.
2. THE TOP OPENING SHALL BE A FULL OPENING HINGED LID. THE HINGE SHALL BE POSITIONED PARALLEL TO THE FLOW THROUGH THE METERING MANHOLE.
3. THE TOP RIM OF THE PREFABRICATED METERING MANHOLE SHALL NOT EXCEED 18 INCHES ABOVE GROUND LEVEL.
4. TWO 4 INCH FRP (FIBERGLASS REINFORCED POLYESTER) TAPS WITH PLUGS, ONE ABOVE GRADE, AND ONE BELOW GRADE, ARE TO BE PLACED THROUGH THE SIDE WALL ABOVE THE INLET PIPE.
5. A 9 x 10 FOOT CONCRETE PAD 6 INCHES THICK AND 2 INCHES ABOVE GRADE SHALL BE CONSTRUCTED SURROUNDING THE MANHOLE. THE SLAB SHALL BE POSITIONED SUCH THAT THE MANHOLE IS CENTERED IN THE 9 FOOT DIMENSION AND OFFSET IN THE 10 FOOT DIMENSION SUCH THAT A 3-FOOT SECTION OF THE SLAB IS ORIENTED OVER THE INLET PIPE AND A 2-FOOT SECTION IS OVER THE OUTLET PIPE.
6. ALLOWABLE SLOPE ENTERING AND EXITING THE METERING MANHOLE SHALL BE LIMITED TO A SPECIFIC MAXIMUM AND MINIMUM AS PER THE FOLLOWING TABLE:

PIPE SIZE	MIN. % SLOPE	MAX. % SLOPE
6"	2.00	2.2
8"	0.70	2.0
10"	0.50	1.8
12"	0.40	1.6
15"	0.30	1.5
18"	0.24	1.4
21"	0.19	1.4

7. NO BENDS, DROP MANHOLES, FLOW JUNCTIONS, ETC. SHALL BE LOCATED WITHIN 25 PIPE DIAMETERS UPSTREAM OF THE CENTER OF THE MANHOLE.
8. DOWNSTREAM SLOPE SHALL BE GREATER THAN OR EQUAL TO UPSTREAM SLOPE. THERE SHALL BE NO OBSTRUCTION DOWNSTREAM OF THE MANHOLE THAT WILL CAUSE FLOW TO BACK UP IN THE MANHOLE.
9. 6' LONG, 4" I.D. CAST IRON GUARD POSTS SHALL BE INSTALLED AS DIRECTED BY THE ENGINEER, TO PREVENT VEHICULAR DAMAGE TO THE METERING MANHOLE. GUARD POSTS SHALL BE FILLED WITH CONCRETE AND INSTALLED 2' DEEP SET IN CONCRETE.
10. THE PARSHALL FLUME SHALL BE APPROPRIATELY SIZED ACCORDING TO MANUFACTURER'S SPECIFICATION AND ANY OTHER ATTACHMENTS NEEDED FOR THE FLOW METER SELECTED. (NOTE: MINIMUM AND MAXIMUM FLOW RATES MUST BE DETERMINED TO SELECT THE APPROPRIATELY SIZED PARSHALL FLUME.)
11. A TWO OUTLET GFCI, 110 VOLT, AC ELECTRICAL SUPPLY SHALL BE SUPPLIED FOR EXCLUSIVE USE BY KID AT THE CONCRETE PAD OR WITHIN FIFTY FEET SO THAT THE ROUTE OF AN EXTENSION CORD WILL NOT CROSS A TRAFFIC ZONE. A FLOW METER SUITABLE FOR SITE SPECIFIC CONDITIONS AND FLOW PATTERNS SHALL BE INSTALLED AT THE METERING MANHOLE, AND MAINTAINED ACCORDING TO THE MANUFACTURER'S SPECIFICATIONS AND THE KID INDUSTRIAL WASTEWATER FLOW METERING AGREEMENT AND REQUIREMENTS. THE OPEN CHANNEL FLOW METER SHALL BE A SIEMENS (MILLTRONICS) OCM III WALL MOUNTED INDICATOR TRANSMITTER, HOUSED IN A NEMA 4X ENCLOSURE COMPLETE WITH ONE WEATHER PROOF POWER OUTLET, LOCATED ON A POLE NEXT TO THE METERING MANHOLE. SYSTEM INCLUDES AN XRS-5 NON-CONTACTING ULTRASONIC LEVEL SENSOR, TS-2 TEMPERATURE SENSOR FOR AUTOMATIC TEMPERATURE COMPENSATION AND A REMOVABLE HAND HELD PROGRAMMER. AN INTERNAL DATA LOGGER, 4-20mA SIGNALS OUTPUT AND (3) PROGRAMMABLE DRY CONTACT ALARM RELAYS SHALL ALSO BE INCLUDED.
12. ANY LOCKING MECHANISM SHALL UTILIZE DUAL LOCKS. ONE KID SUPPLIED LOCK IN ADDITION TO ANY PLACED BY THE USER.
13. KID MUST APPROVE THE MANHOLE AND METERING SYSTEM PRIOR TO INSTALLATION, AND ALL OTHER TERMS AND CONDITIONS OF KID.

WIDTH "W"	HA HEAD FEET	MINIMUM FLOW RATE			HA HEAD FEET	MAXIMUM FLOW RATE		
		CFS	MGD	GPM		CFS	MGD	GPM
1	0.07	0.005	0.003	2.2	0.6	0.15	0.10	68.7
2	0.07	0.011	0.007	4.9	0.6	0.31	0.20	137
3	0.10	0.028	0.018	12.6	1.5	1.86	1.20	835
6	0.10	0.054	0.035	24.2	1.5	3.91	2.53	1750
9	0.10	0.091	0.059	40.8	2.0	8.87	5.73	3980
12	0.10	0.120	0.078	53.9	2.5	16.10	10.40	7220
18	0.10	0.174	0.115	78.1	2.5	24.60	15.90	11000
24	0.15	0.423	0.273	190.0	2.5	33.10	21.40	14900
36	0.15	0.615	0.397	276.0	2.5	50.40	32.60	22600

DRAWN:
JW
CHECKED:
RL
CHECKED:



Sewer Metering Manhole Requirements

DATE:
7-24-2024
DRWG NO.:
S13

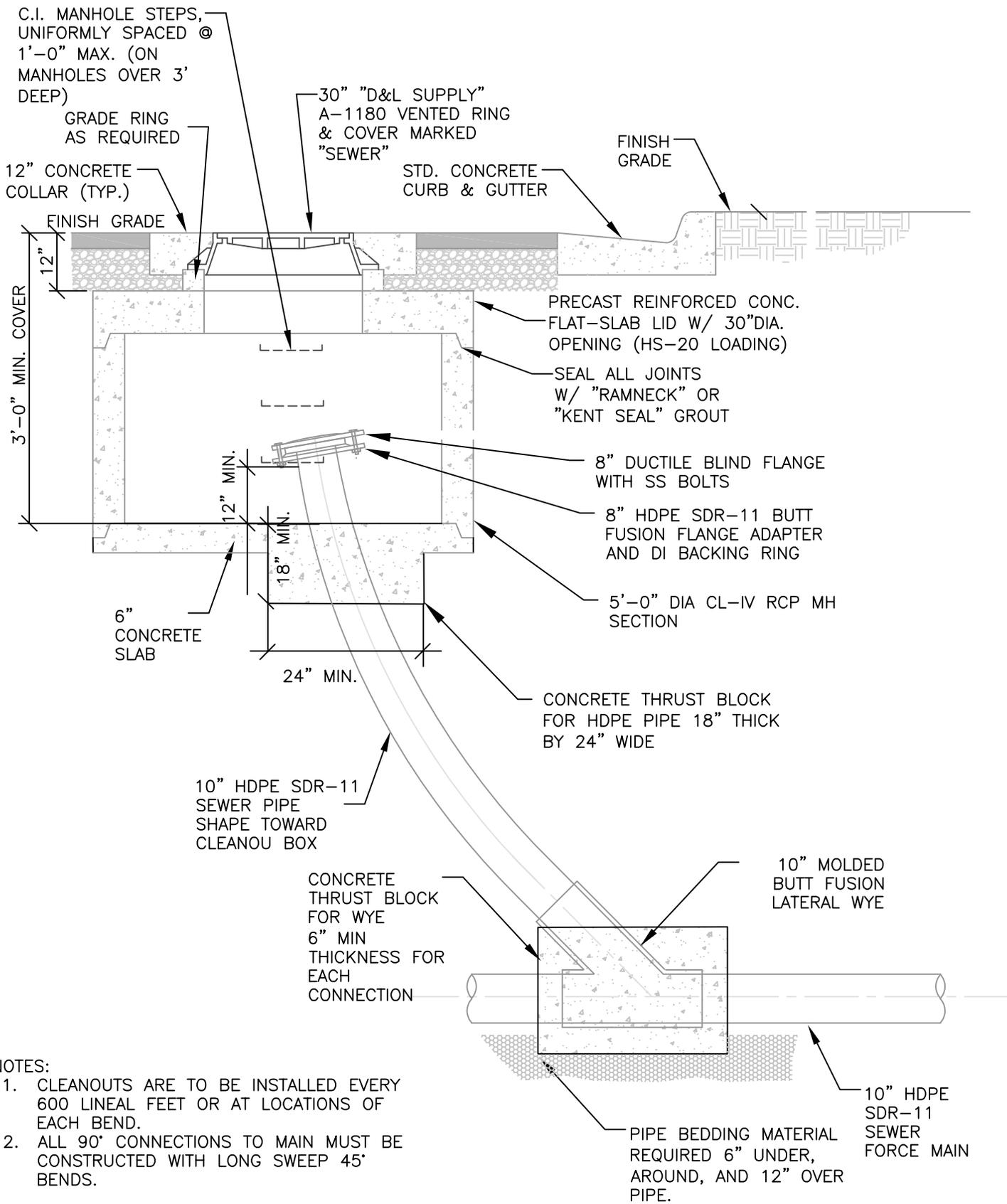

NOTES:

- CLEANOUTS ARE TO BE INSTALLED EVERY 600 LINEAL FEET OR AT LOCATIONS OF EACH BEND.
- ALL 90° CONNECTIONS TO MAIN MUST BE CONSTRUCTED WITH LONG SWEEP 45° BENDS.

DRAWN:	JW
CHECKED:	RL
CHECKED:	



CLEANOUT - SEWER FORCE MAIN

Detail

DATE:	7-24-2024
DRWG NO.:	S14